

TAB. 1



CASA AUTO	MODELLO	PORTE	ANNO
FIAT	500	3	07>15
FIAT	500	3	15>
FIAT	Fullback	4	15>
HONDA	CR-V III	5	06>12
LANCIA	Ypsilon	3	04>11
MITSUBISHI	L200 / Triton V	4	15>

M1	M2
12,0	8,7
12,0	8,7
8,5	7,5
10,2	8,4
12,3	10,5
8,5	7,5

G1	F1	G2	F2
06	B	02	A
06	B	02	A
06	B	02	A
06	B	02	A
06	B	02	A
06	B	02	B

T1	T2
X	7
X	7
20	50
14	45
X	X
20	50

Le tabelle di applicabilità sono soggette ad invecchiamento e/o modifiche, in caso di dubbio si consiglia di consultare il sito www.k39.it costantemente aggiornato.
The applicability tables are subject to aging and/or changes, in case of doubt it is advisable to consult the constantly updated website www.k39.it.

X = predisposizione originale



GUARDA
IL
VIDEO



WATCH
THE
VIDEO

1

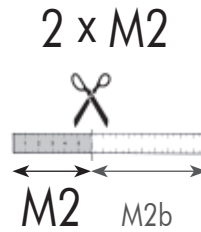
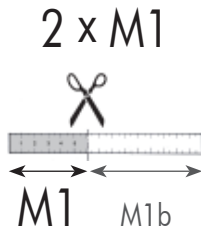
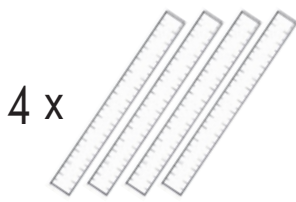

 Tab. 1:
M1
M2

Tagliare i 4 metri in dotazione alla misura M1 ed M2 riportate in tabella

2

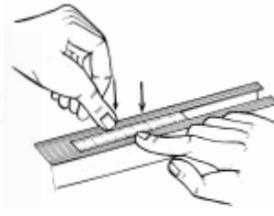
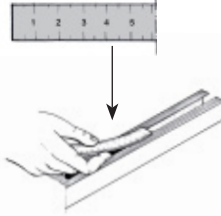

M1 - M2



Inserire il metro tagliato in misura M1 nelle 2 cave della barra anteriore, portandolo fine a fine corsa.
Ripetere l'operazione per la barra posteriore con i metri tagliati in misura M2.

3



Prendere i 4 piedi dalla scatola, allentare la vite affinché i piedi possano entrare nella cava.
Prendere il primo piede ed inserirlo in cava facendo **ATTENZIONE** a non sormontare il metro precedentemente inserito, stringere con forza la vite del piede.
Ripetere l'operazione per tutti i 4 piedi ciascuno in una cava.

5 Nm

K1

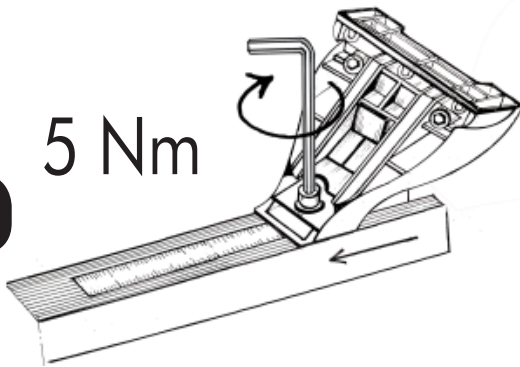

5 Nm

K1pro

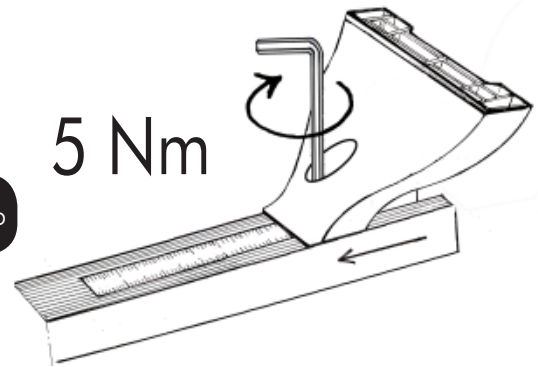

4

M1b - M2b

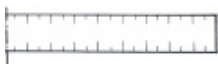

Inserire l'avanzo del metro tagliato (M1b per la barra anteriore ed M2b per la barra posteriore) per coprire la cava scoperta.

Ripetere l'operazione per tutte e 2 le barre.
Inserire, infine, i 4 tappi come indicato in figura.

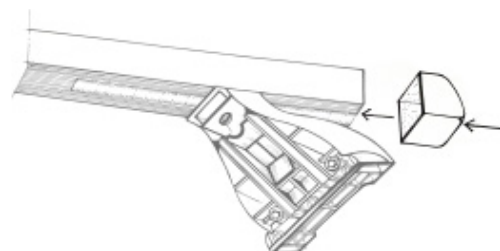
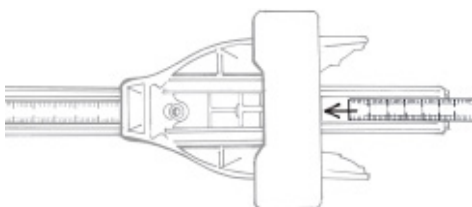

5

 Tab. 1:
G1-F1
G2-F2

4 x

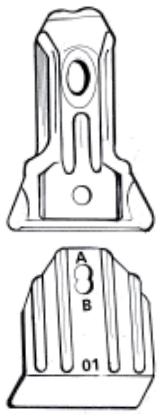

8x14

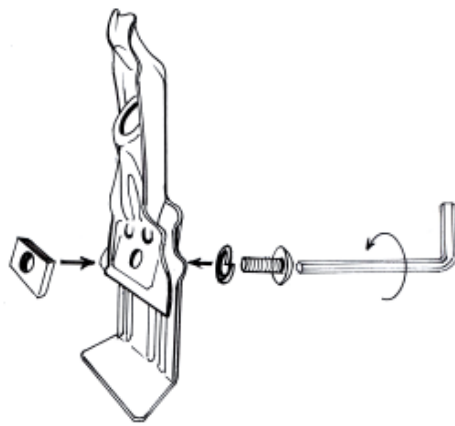

Assemblare le 4 GANASCINE come mostrato in figura, facendo **ATTENZIONE** a rispettare le misure riportate in tabella. Lasciare la parte inferiore della ganascina lasca.

6

8x50

4 x

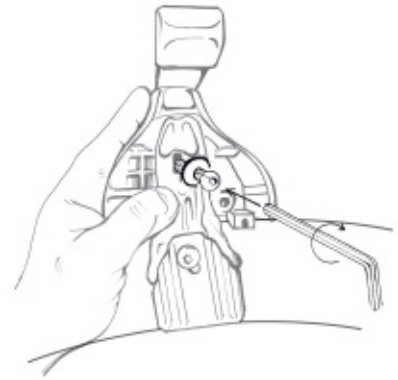
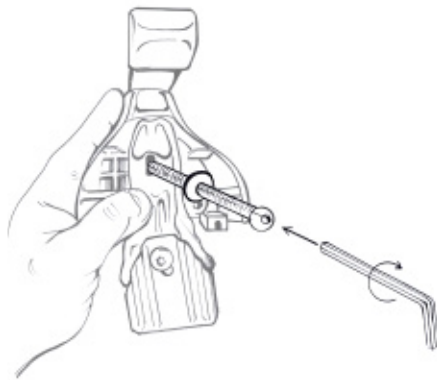

Posizionare la barra anteriore e la barra posteriore sul tetto dell'autovettura. Fissare le ganascine ai 4 piedi facendo **ATTENZIONE** a non stringere completamente la vite.

7

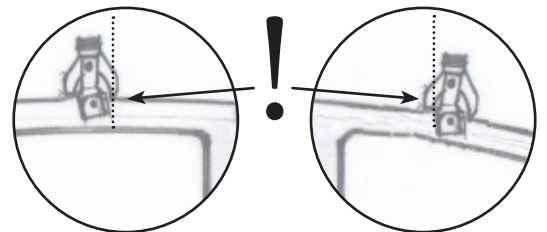
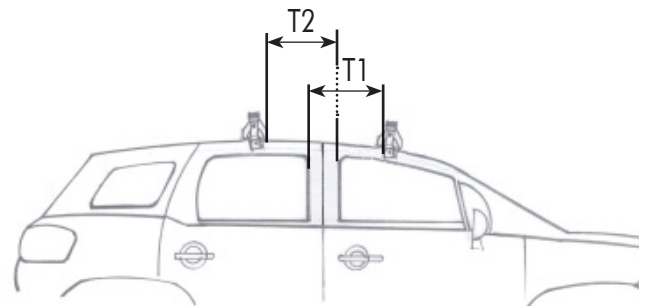
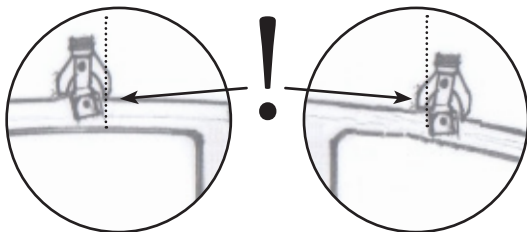
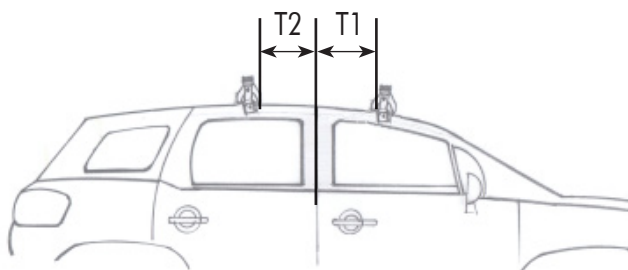
 Tab. 1:
T1
T2

8

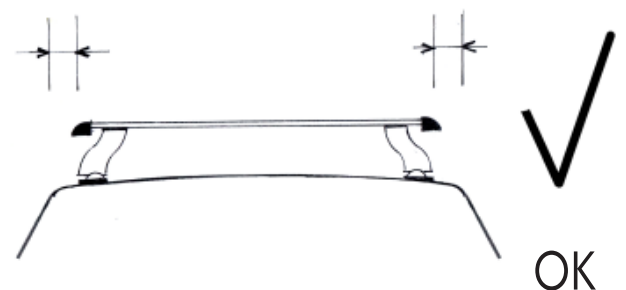
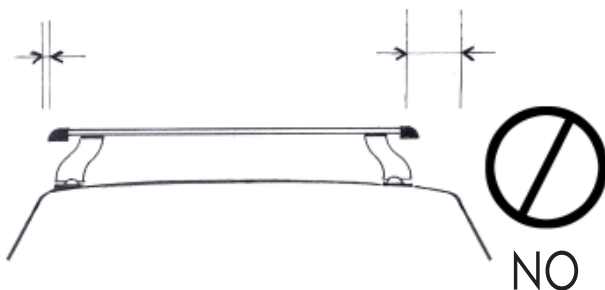

9

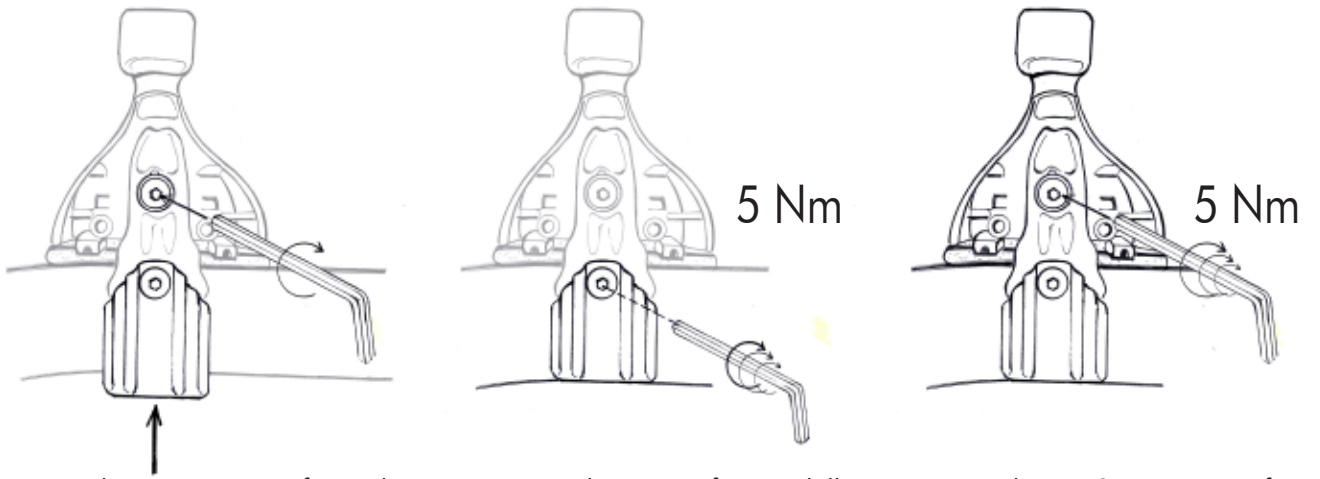

Stringere la vite superiore fino ad accompagnare la parte inferiore della ganascina al tetto. Stringere con forza la vite inferiore. Stringere con forza la vite superiore facendo **ATTENZIONE** a non spostare la centratura delle barre. Per ottenere il risultato corretto stringere le viti alternando il lato destro al lato sinistro in maniera uniforme.

10a



K1



x 4

10b



K1pro





x 4

MAX
55 kg

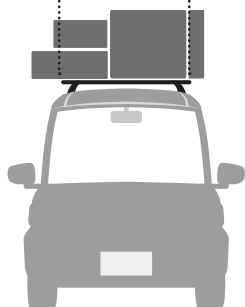

 NO



 OK



 NO

