

CASA AUTO	MODELLO	PORTE	ANNO
AUDI	A1 (XA) Sportback restyling	5	14>18
LANCIA	Ypsilon II	5	15>21
LANCIA	Ypsilon III	5	21>
RENAULT	Arkana	5	19>
RENAULT	Austral	5	22>
RENAULT	Captur	5	13>17
RENAULT	Clio IV	5	12>19
RENAULT	Clio V	5	19>
RENAULT	Rafale	5	23>
RENAULT	Twingo III	5	14>

M1	M2
3,8	4,5
14,7	14,1
14,7	14,1
9,5	7,9
11,9	10,2
6,2	3,7
4,9	3,9
7,5	6,3
11,8	10,5
6,2	3,9

G1	F1	G2	F2
10	B	10	A
10	B	10	A
10	B	10	A
10	B	10	A
10	B	10	B
10	B	10	A
10	B	10	A
10	B	10	B
10	B	10	B
10	B	10	A

T1	T2
X	X
X	X
X	X
X	X
X	X
X	X
X	X
X	X
X	X
X	X

X = predisposizione originale



Le tabelle di applicabilità sono soggette ad invecchiamento e/o modifiche, in caso di dubbio si consiglia di consultare il sito www.k39.it costantemente aggiornato.
The applicability tables are subject to aging and/or changes, in case of doubt it is advisable to consult the constantly updated website www.k39.it.



GUARDA
IL
VIDEO



WATCH
THE
VIDEO

1



Tab. 1:
M1
M2

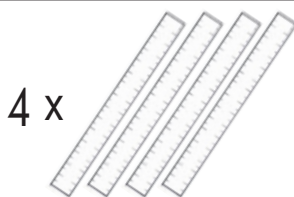

4 x

2 x M1

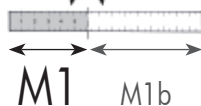

2 x M2

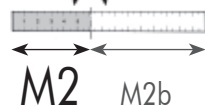

Tagliare i 4 metri in dotazione alla misura M1 ed M2 riportate in tabella

2

2 x



M1 - M2

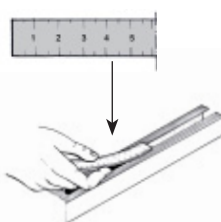

Inserire il metro tagliato in misura M1 nelle 2 cave della barra anteriore, portandolo fine a fine corsa.
Ripetere l'operazione per la barra posteriore con i metri tagliati in misura M2.

3

4 x

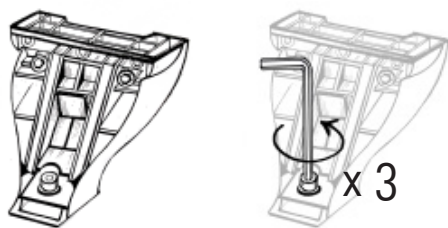

Prendere i 4 piedi dalla scatola, allentare la vite affinché i piedi possano entrare nella cava.

Prendere il primo piede ed inserirlo in cava facendo **ATTENZIONE** a non sormontare il metro precedentemente inserito, stringere con forza la vite del piede.

Ripetere l'operazione per tutti i 4 piedi ciascuno in una cava.

5 Nm

K1

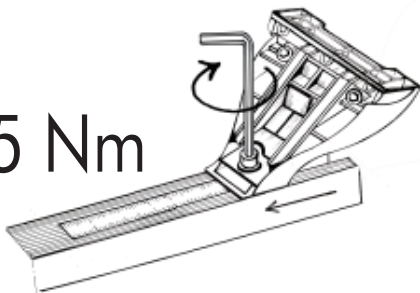

5 Nm

K1pro

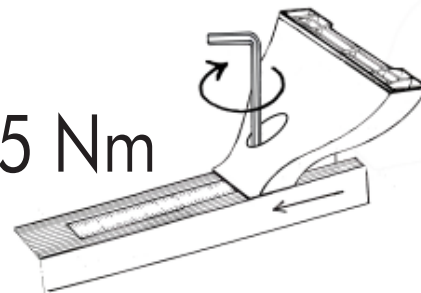

4

M1b - M2b

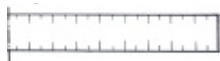

Inserire l'avanzo del metro tagliato (M1b per la barra anteriore ed M2b per la barra posteriore) per coprire la cava scoperta.

Ripetere l'operazione per tutte e 2 le barre.

Inserire, infine, i 4 tappi come indicato in figura.

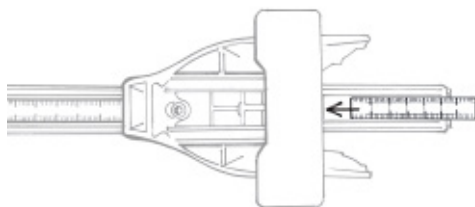

5



Tab. 1:
G1-F1
G2-F2

4 x

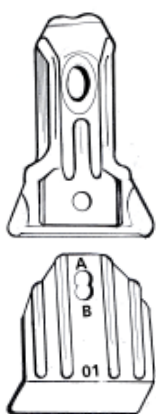

8x14

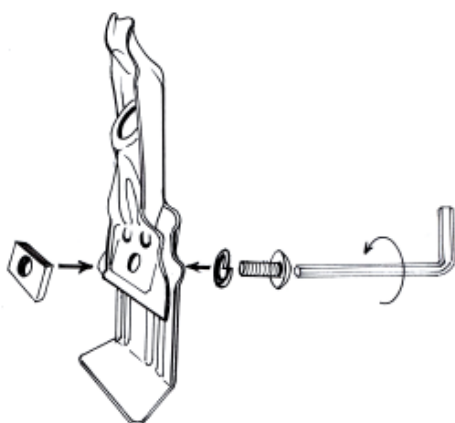

Assemblare le 4 GANASCINE come mostrato in figura, facendo **ATTENZIONE** a rispettare le misure riportate in tabella.

Lasciare la parte inferiore della ganascina lasca.

6

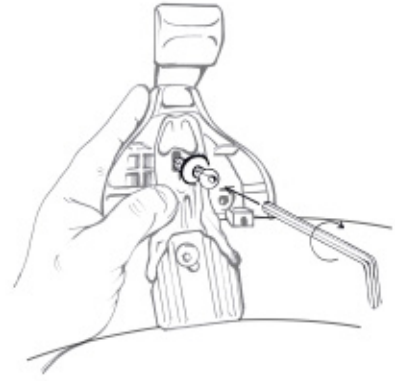
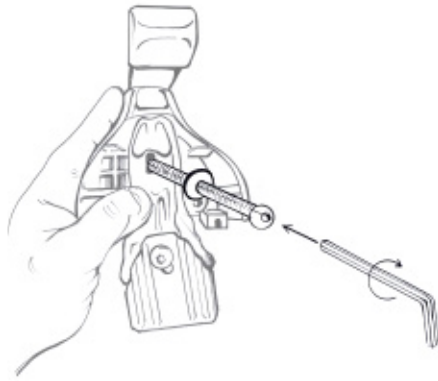

Posizionare la barra anteriore e la barra posteriore sul tetto dell'autovettura. Fissare le ganascine ai 4 piedi facendo **ATTENZIONE** a non stringere completamente la vite.

7

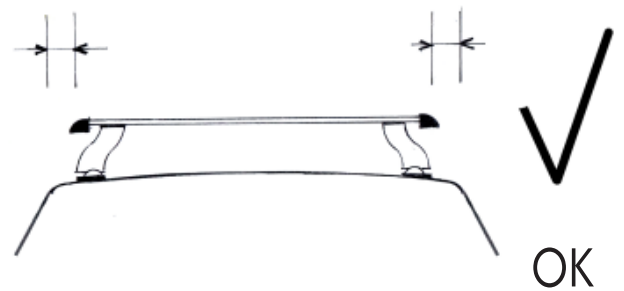
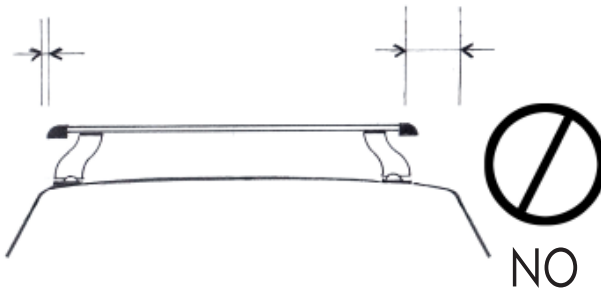

8

4 x
6x16

CASA AUTO	MODELLO	PORTE	ANNO
AUDI	A1 (XA) Sportback	5	14→
LANCIA	Ypsilon	5	15→
RENAULT	Arkana	5	19→
RENAULT	Captur	5	13→17
RENAULT	Clio IV	5	12→16
RENAULT	Clio IV	5	16→
RENAULT	Clio V	5	19→
RENAULT	Twingo III	5	14→



GUARDA
IL
VIDEO



WATCH
THE
VIDEO

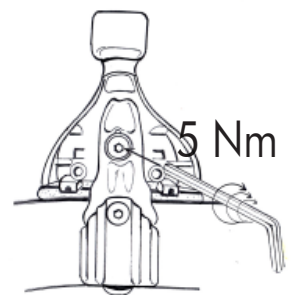
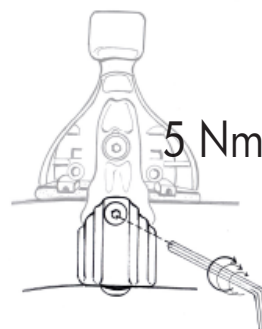
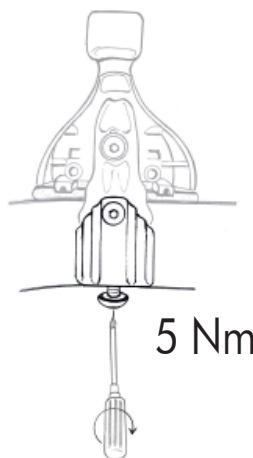
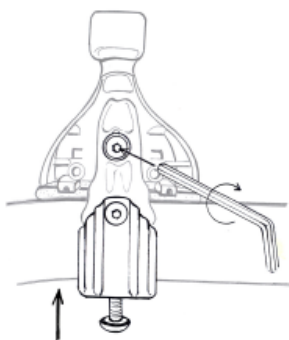

Stringere la vite superiore fino ad accompagnare la parte inferiore della ganascina al tetto. Stringere la vite inferiore arrivando a fine corsa. Stringere con forza la vite di congiunzione della ganascina. Stringere con forza la vite superiore facendo **ATTENZIONE** a non spostare la centratura delle barre. Per ottenere il risultato corretto stringere le viti alternando il lato destro al lato sinistro in maniera uniforme.

9a



K1



x 4

9b



K1pro



x 4

MAX
55 kg

